



LACTATE DETECTION USING MICROWAVE SPECTROSCOPY FOR IN-SITU MEDICAL APPLICATIONS

J. H. Goh¹, A. Mason¹, A. I. Al-Shamma'a¹, M. Field², P. Browning²

¹Built Environment and Sustainable Technologies (BEST) Research Institute,
Liverpool John Moores University,
Henry Cotton Building, 15-21 Webster Street, Liverpool, L3 2ET, UK.

²Liverpool Heart and Chest Hospital – NHS Foundation Trust
Thomas Drive, Liverpool, L14 3PE, UK.

Email: j.h.goh@2006.ljmu.ac.uk

Submitted: June 30, 2011

Accepted: July 30, 2011

Published: September 1, 2011

Abstract –Lactate is an indicator of neurological impairment during aortic aneurysm surgery, and thus its detection could provide the basis for improved treatment regimes, better quality of care, and enhanced resource efficiency within the UK National Health Service (NHS). This article considers the use of low power microwave sensors to detect varying lactate concentrations in distilled water; sample sizes of 10ml and 0.5ml are considered via two sensor designs. Microwave sensors provide a rapid non-invasive method of material analysis, which is robust and cost-effective, in addition to harbouring huge potential for a wide range of biomedical applications.

Index terms: microwave, cavity, sensor, lactate, cerebrospinal fluid.

I. INTRODUCTION

This research is part of a collaborative effort between Liverpool John Moores University (LJMU) and Liverpool Heart and Chest Hospital (LHCH), whereby LHCH are responsible for the preparation of samples and LJMU analyse the samples via microwave spectroscopy methods. The work has many associated strands, however it has commenced with the analysis of cerebrospinal fluid (CSF).

CSF is a clear, colourless bodily fluid produced in the brain which occupies the subarachnoid space and the ventricular system around and inside the brain and spinal cord. CSF is produced at a rate of 0.2-0.7ml/min, or approximately 600-700ml/day; it provides buoyancy for the brain and protects it from injury in the event of jolting. In addition it plays an important role in the homeostasis and metabolism of the central nervous system since it rinses metabolic waste through the blood brain barrier and back into the bloodstream.

Patients who are undergoing surgical or endovascular aneurysm repair (EVAR) of acute and chronic thoraco-abdominal aortic disease [1,2] have an inherent risk of paraplegia. This is caused by restriction of the spinal cord blood flow and lack of oxygen during the procedures. This situation is referred to as spinal cord ischemia [3,4]. Currently, CSF is removed from the patient via a spinal drain in order to relieve any pressure and therefore reduce the risk of paraplegia. This CSF is discarded as waste typically, but researchers at LHCH believe that it could contain significant information regarding the patient; it could be used to indicate sub-clinical cord ischemia and compromise [5], for example.

CSF contains a number of proteins, such as glucose, albumin and lactate [6]. Thus far, this work concentrates on the lactate element of CSF. The normal physiological level of lactate in blood or CSF is approximately 1mM. In pathology it may rise to around 10-15mM, or in exercise even higher [7]. It is assumed for the purposes of this study that patients with significant (i.e. in the region of 10mM) quantities of lactate in their CSF may be suffering from conditions such as sub-clinical cord ischemia. Therefore, researchers at LJMU and LHCH are interested in developing a method with the ability to rapidly analyse CSF during surgical procedures in order to give

surgeons information upon which they may act quickly. This has the potential to reduce further invasive procedures for that patient, whilst increasing hospital efficiency, allowing them to serve other patients.

Microwave analysis (or microwave spectroscopy) has a range of advantages for biomedical applications. It is a non-ionising technique utilising low power output at around 1mW (0dBm) but has good penetration depth and equipment can be portable for use at the bedside. The multi-parameter nature of broadband microwave analysis can provide unique signal spectrum signatures which are a reflected signal, $|S_{11}|$, and/or a transmitted signal, $|S_{21}|$, based on parameters such as conductivity and permittivity [8]. Conductivity is a measurement of a material's ability to conduct an electric current. Permittivity is a measurement of how an electric field is affected by a dielectric medium, which is determined by the ability of a material to polarise in response to the field, and reduce the total electric field inside the material. Therefore, permittivity relates to a material's ability to transmit an electric field and is a complex value which varies with changing frequency, and accounts for both the energy stored by a material (ϵ') as well as any losses of energy (ϵ'') which might occur.

As a precursor to testing on human samples, this work looks at the microwave response of varying levels of lactate in water, to determine whether it can indeed be used as a marker of ischemia in CSF. This is partly due to lactate being inexpensive, in addition to CSF providing a relative simple background which provides a good basis for working with human samples.

The remaining parts of this paper consider the theory of operation underpinning the work, the experimental procedures undertaken and also the results obtained from the work.

II. MICROWAVE THEORY AND OPERATION

As a material alters in concentration or type, it is likely that its permittivity will change. This leads to a change in response if the material is the target of microwave radiation. By measuring this change in response over a range of frequencies, one can characterise materials in order to infer their properties. Figure 1 depicts the basic principles of a microwave cavity, showing the

dielectric components: (1) the air within the cavity, (2) the sample container and (3) the sample itself.

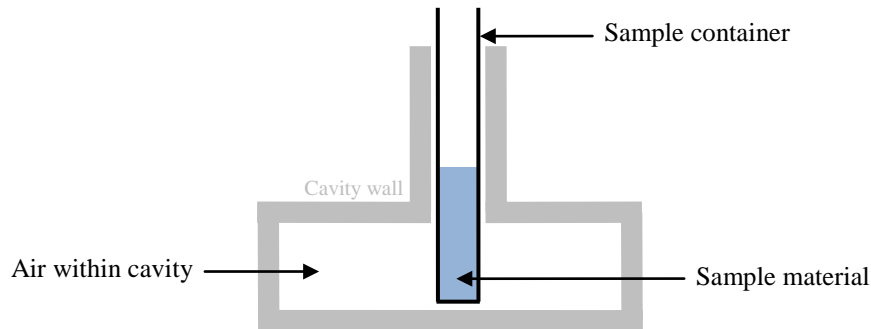

Figure 1: The microwave analysis method, showing the basic cavity overview along with the three major dielectric materials present during sampling.

The work undertaken by researchers at LJMU is based upon this notion, and aims to provide evidence that biological materials (lactate in this case) can be analysed using microwave spectroscopy in order to determine parameters which could lead to improved patient care. As mentioned earlier, such improvements could be realised via real-time information being made available during surgical procedures, in addition to rapid analysis of material in order to determine a course of remedial action for a patient.

Microwave cavities are widely used for characterising the dielectric properties of materials [9,10]. A cavity is usually made by shorting the two ends of a segment of waveguide, and will resonate when it is excited at an appropriate frequency. The electrical power is transported through the cavity by means of microwaves, which can take several different forms (modes). The resonant modes [11] occur when the electric and magnetic fields form standing waves, which depend on the internal dimensions of the cavity and the dielectric properties of any material contained within the cavity. The transverse electric (TE) and transverse magnetic (TM) are the two types of mode which exist in any waveguide.

If the material contained within the cavity changes, then it follows that its relative permittivity (ϵ_r) will change. Thus by considering equation (1), which allows one to calculate the resonant frequency for TE_{nml} and TM_{nml} modes [12] in a circular waveguide, it is clear that a change in

permittivity will result in a change in resonant frequency. This is due to the reliance of TE and TM modes on $\sqrt{\epsilon_r}$, and therefore results in resonant peaks shifting to lower frequencies as permittivity increases.

$$f_{nml} = \frac{c}{2\pi\sqrt{\mu_r\epsilon_r}} \sqrt{\left[\left(\frac{p_{nm}}{a}\right)^2 + \left(\frac{l\pi}{d}\right)^2\right]} \quad (1)$$

where:

c is the speed of light

μ_r is of the relative permeability

ϵ_r is the relative permittivity

p_{nm} is the value of the Bessel function for the TE or TM modes of a circular waveguide

a is the radius of the cavity

d is the height of the cavity

III. EXPERIMENTAL METHODOLOGY

a. Microwave Cavities

Two microwave cavities have been designed and used for this research. These are shown in Figure 2; (a) shows a cavity designed to accept large volume samples, and (b) shows a cavity designed to accept smaller volumes. Ultimately the latter is preferential in medical situations since the availability of many biological materials is minimal; CSF however is an exception to this rule, with 10-15ml being readily available from patients as a result of the draining procedure which takes place during surgical or endovascular aneurysm repair at LHCH. The samples are discussed further later in the paper.

The large volume cavity is capable of analysing samples of up to 15ml in volume – smaller sample sizes are possible, however since the sample receptacle is fully immersed in the cavity the sample volumes must be identical for reliable comparison. This cavity has two ports, therefore allowing simple measurement of the $|S_{11}|$ and $|S_{21}|$ spectra.

The smaller volume cavity can accept sample receptacles of up to 2.3ml in volume, however the internal height of the cavity means that practically only the lowest 0.5ml of that volume is

analysed. Therefore, provided the sample container is filled to a volume greater than 0.5ml in this case, accurate filling is not necessary. This cavity has *three* ports; two opposite one another on the exterior of the cylinder and one also directly beneath the sample container which feeds a patch antenna within the cavity (Figure 2(c) shows this element). This patch antenna is the means by which microwaves are launched into the cavity. Only the later port is used in this work, therefore meaning that $|S_{11}|$ measurement only is possible with this cavity. In order to minimise any disturbance from the unused ports they are fitted with 50Ω matched loads during experimentation.

The TE and TM modes for both of the cylindrical cavities used for this work can be simulated in Ansoft's HFSS software [13,14], which is ideal for simulating complex geometries for applications such as that proposed in this paper. Figure 3 and 4 show the field configurations for the first two modes in the empty large and small volume cavity respectively. The red and blue regions in these figures represent the maximum and minimum field intensities respectively. Table 1 gives details of the first two modes for each cavity when empty.

Table 1: Details of the first two modes for the large and small volume cylindrical cavities used in this work.

	First mode			Second Mode		
	<i>Freq.</i> (GHz)	<i>Mode</i>	<i>Shown in</i> <i>figure...</i>	<i>Freq.</i> (GHz)	<i>Mode</i>	<i>Shown in</i> <i>figure...</i>
Large volume cavity	2.434	TE ₁₁₁	3(a)	2.565	TM ₀₁₀	3(b)
Small volume cavity	1.789	TM ₀₁₀	4(a)	2.850	TM ₁₁₀	4(b)



(a)



(b)

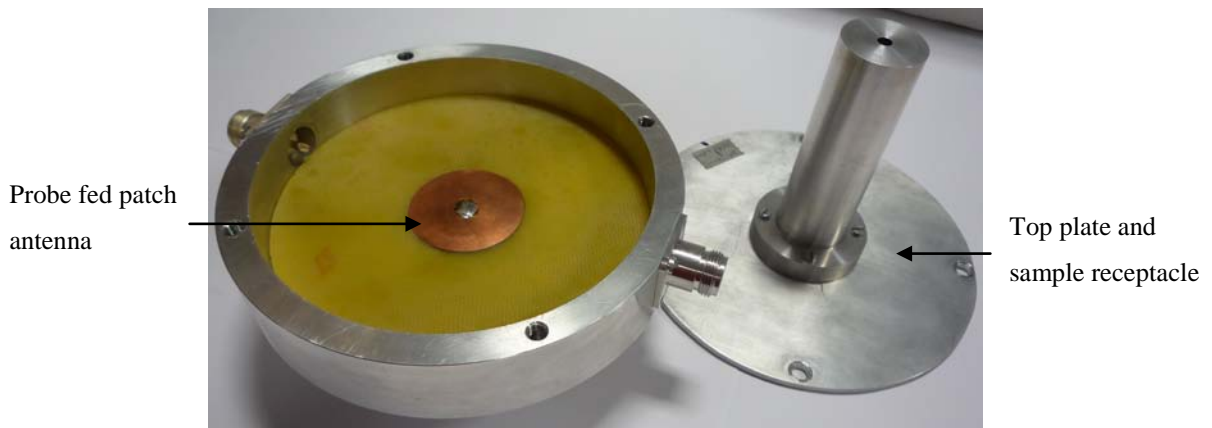

(c)

Figure 2: Two cavities have been used during this research work in order to test a different volume of sample, (a) large volume cavity, (b) small volume cavity. The innards of the small volume cavity are shown in (c).

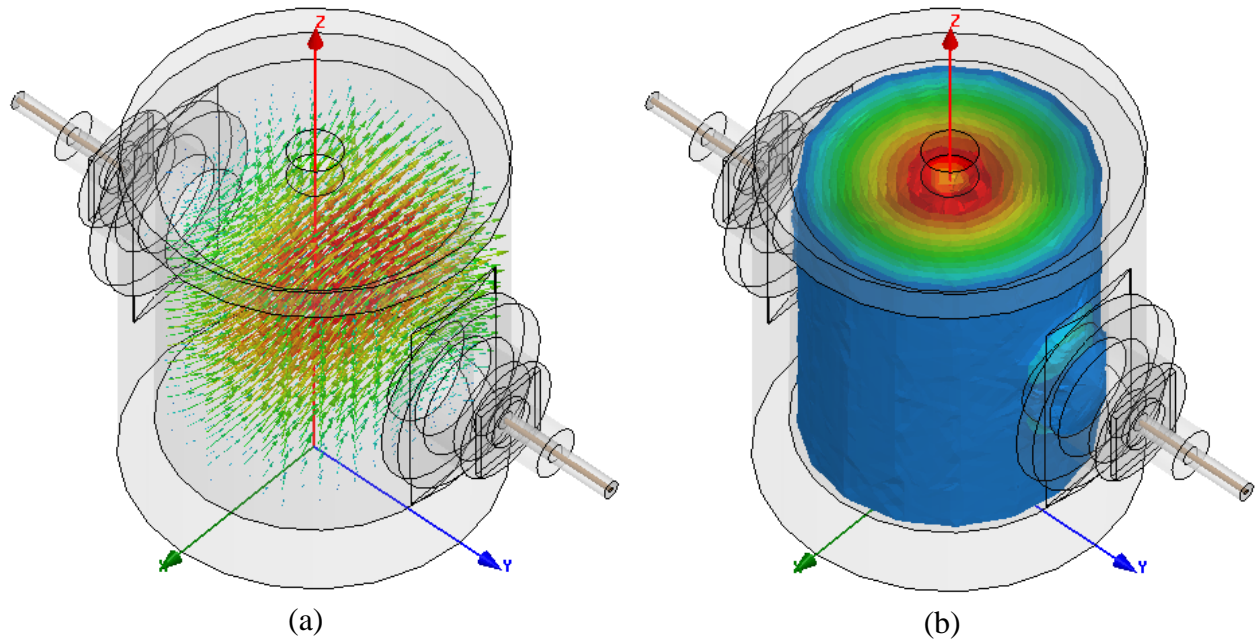

Figure 3: TE and TM modes in the empty large volume cavity, (a) TE_{111} , (b) TM_{010}

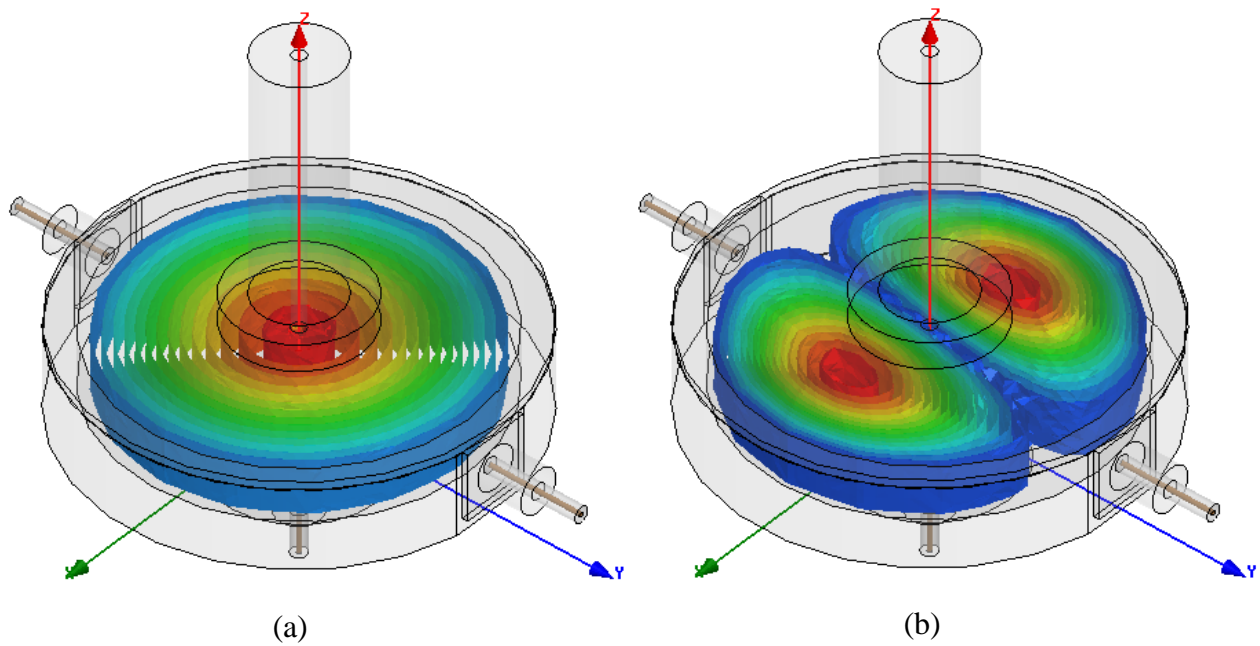

Figure 4: TM modes in the empty small volume cavity, (a) TM_{010} , (b) TM_{110}

b. Lactate Preparation

LHCH has taken responsibility for preparing all of the samples used in this work, and they send them to LJMU laboratories for analysis. Serial dilutions of L(+)-lactic acid were prepared to cover a range from low, physiological and supra-physiological levels (0-64mM) in distilled water. Sample concentrations were as follows: 0mM (distilled water), 0.5mM, 2mM, 4mM, 8mM, 16mM, 32mM, 64mM and 1M.

The samples were stored in both 15 ml polypropylene centrifuge tubes and 2.3ml glass tubes, as shown in Figure 5(a) and 5(b) respectively. The former contained 10ml of fluid, whilst the later contained 0.5ml.

All of the samples were stored in a refrigerated unit at 5°C. Samples were removed only to be exposed to the cavity for a short period of time, after which they were returned to the refrigerator. Prior to testing, samples were inspected briefly for spoiling (e.g. due to bacterial growth).

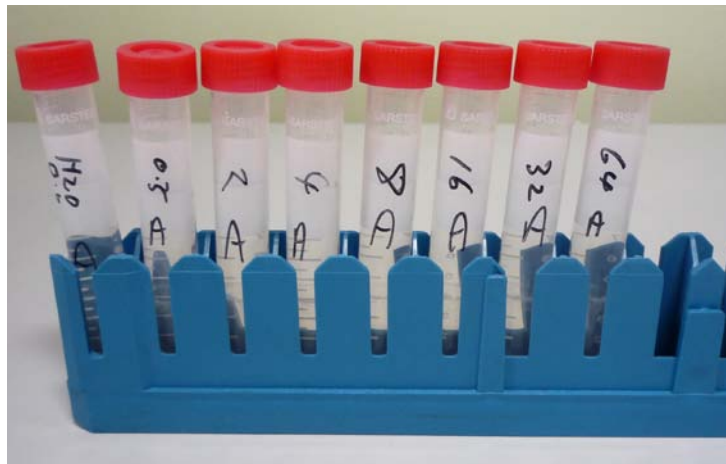

(a)

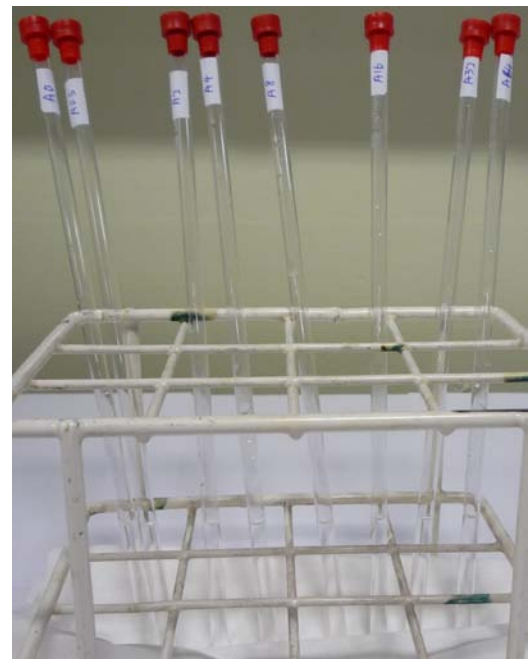

(b)

Figure 5: Shows the lactate samples provided by LHCH in (a) 15ml polypropylene centrifuge tubes, and (b) 2.3ml glass tubes, utilised to fit the large and small volume cavities respectively.

c. Equipment Setup

All measurements were performed using a ZVL-6 Rohde and Schwarz Vector Network Analyser (VNA). The instrument can generate and sample frequencies up to 6GHz. The full spectrum was swept for each sample, although results shown later are related to areas within the spectrum which are of interest. Figure 6 shows the experimental setup for lactate measurement using the large volume cavity; the only difference between this setup and that of the small volume cavity is the single coaxial connection (instead of dual connection, as shown in Figure 6) between the cavity and VNA. Temperature variations were minimised through the use of an environmental chamber set to an arbitrary constant temperature of 20°C.

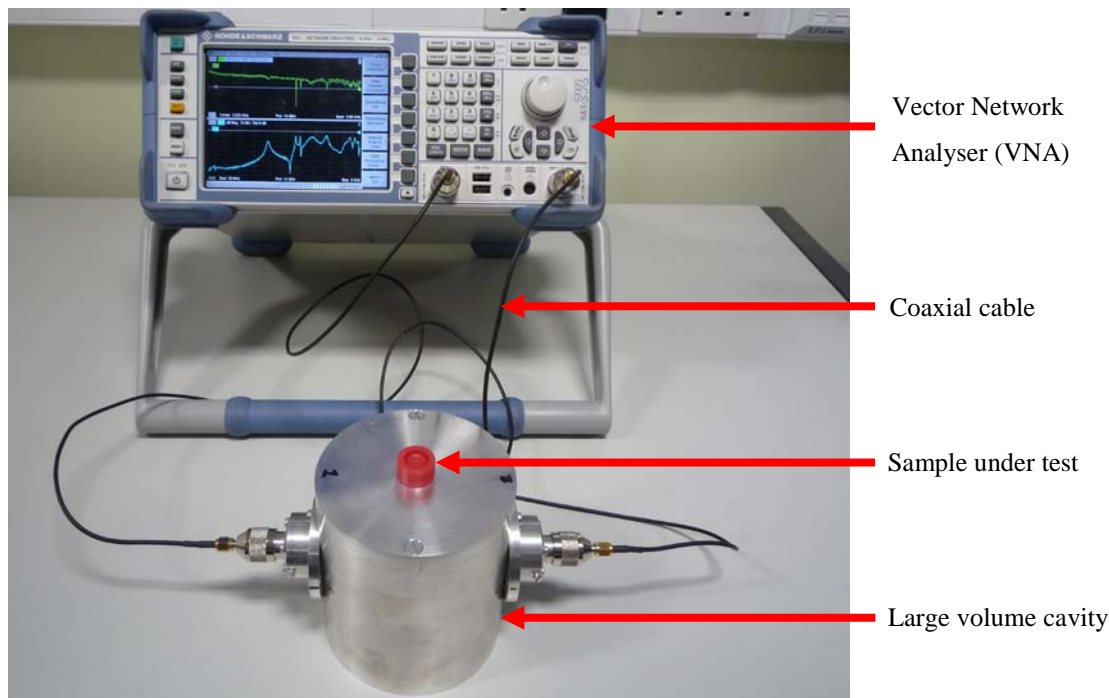

Figure 6: A sample of lactate in water analysed using the large volume cavity, showing the major components of the experimental setup.

IV. EXPERIMENTAL RESULTS

a. Large volume cavity

Figure 7 shows the $|S_{11}|$ spectrum for the large volume cavity, which was used to analyse the 10ml samples. From this spectrum, one can see the level of amplitude decrease as the concentration of the lactate increases from 0mM (distilled water) to 64mM at 3.461GHz. These

results demonstrate a linear sensor response to varying concentrations of lactate in distilled water. The highest amplitude (-27.31dB) occurs when analysing the 0mM sample, whilst the lowest occurs for the 64mM sample (-29.85dB). Across the complete sample set, the amplitude decreases with lactate concentration at a rate of 0.04dB/mM.

The mode at which this response occurs can be determined by matching the measured resonance to that of the simulated model in HFSS. Unlike in section III however, it is necessary to include the sample container with 10ml water in the model in order to determine the correct mode. Figure 8 shows the simulated model for the large volume cavity at 3.458GHz, where the TE_{211} mode dominates. Whilst there is 3MHz difference between simulated and measured resonance, this is considered to be a tolerable error which does not impact on mode determination.

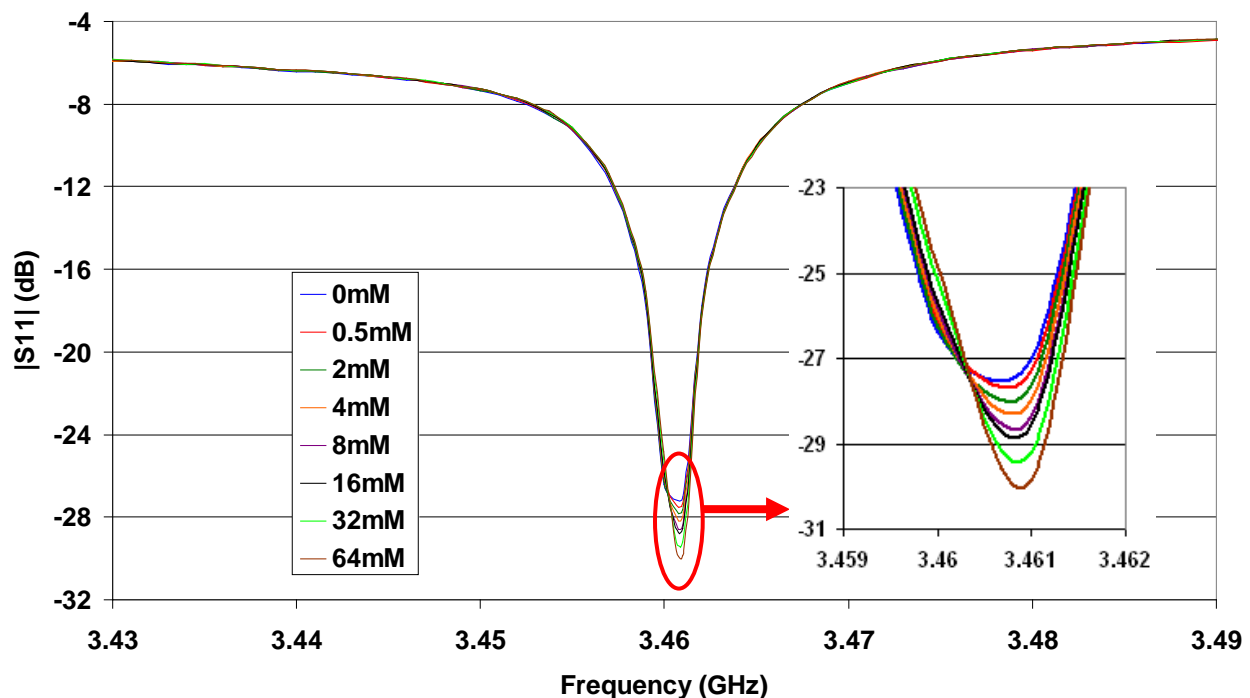

Figure 7: The $|S_{11}|$ spectrum for 10ml lactate in distilled water using the large volume cavity; the frequency range of interest here is 3.43-3.49GHz, with resonance occurring at 3.461GHz.

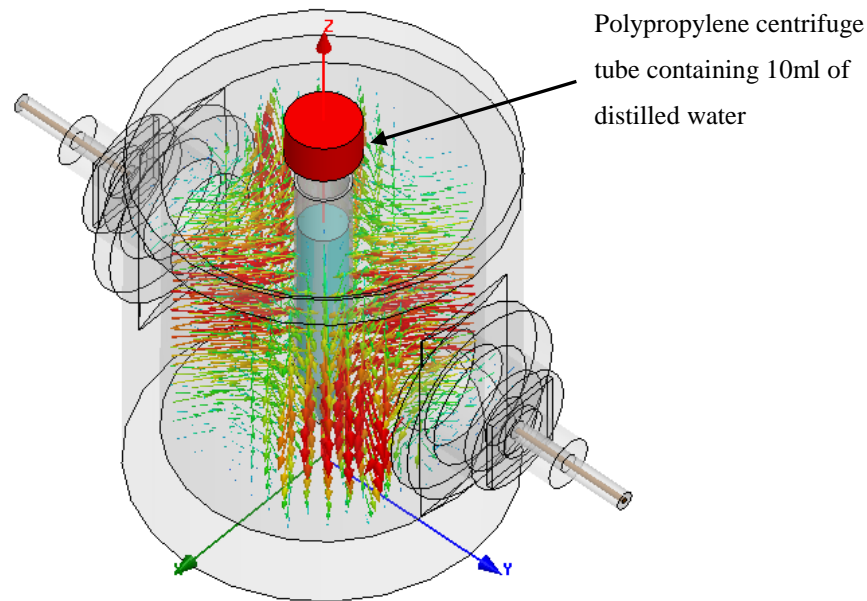

Figure 8: TE_{211} mode for large volume cavity, simulated with a water sample at the centre.

b. Small volume cavity

Figure 9 shows the $|S_{11}|$ spectrum for the small volume cavity, which was used to analyse the 0.5ml samples. From this spectrum result, one can see the level of amplitude increase as the concentration of the lactate increases from 0mM (distilled water) to 64mM at around 1.625GHz. It is difficult to give a definitive figure here since the frequency shifts with concentration in a non-linear way. These results do however show a linear trend for signal amplitude when the concentration of lactate varies in water. The lowest amplitude (-13.62dB) occurs when analysing the 0mM sample, whilst the highest amplitude (-9.33dB) occurs for 64mM sample. Across the complete sample set, the amplitude increases with lactate concentration at a rate of 0.067dB/mM.

As described with the large volume cavity, it is possible to determine the mode at which this response occurs by matching the measured resonance to that of the simulated model in HFSS, which now includes the sample container with 0.5ml of water. Figure 10 shows the simulated model for the small volume cavity at 1.624GHz, where the TM_{010} mode dominates. In this case the error between the measured and simulated resonance is 1MHz, which is better than before and therefore acceptable.

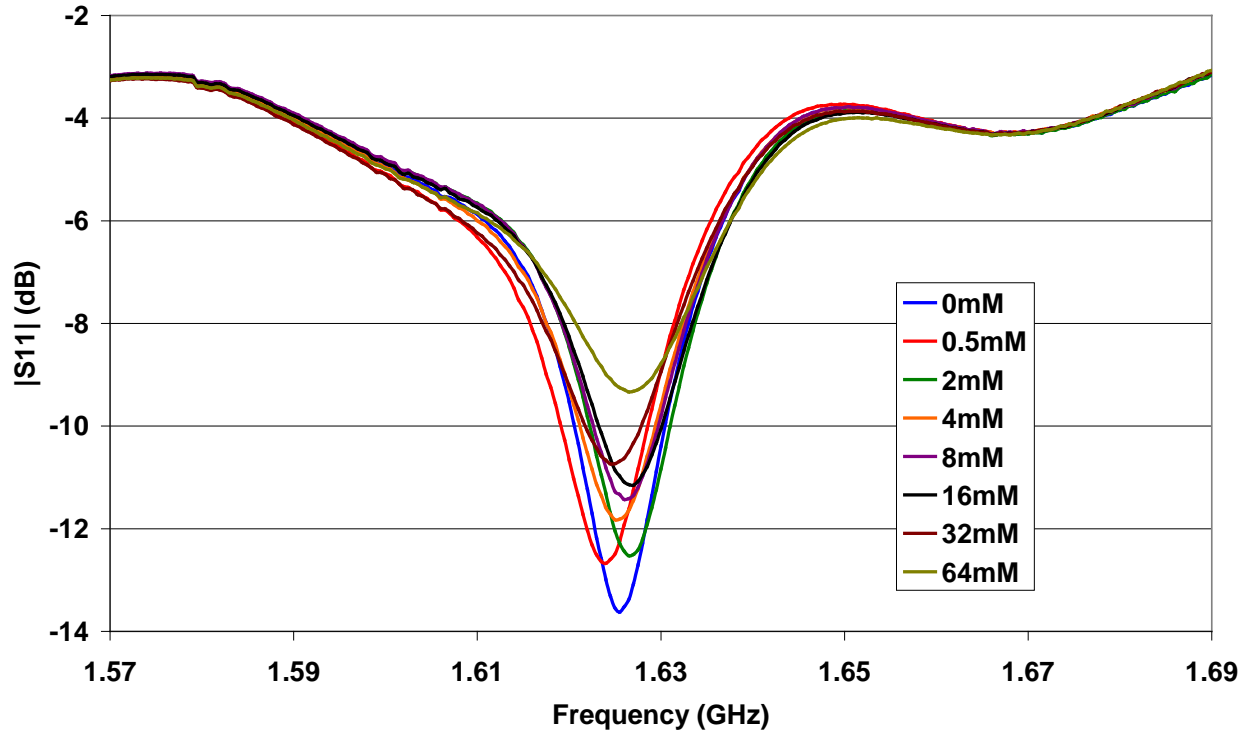

Figure 9: The $|S_{11}|$ spectrum for 0.5ml lactate in distilled water by using the small volume cavity; the frequency range of interest here is 1.57-1.69GHz, with resonance occurring at 1.625GHz.

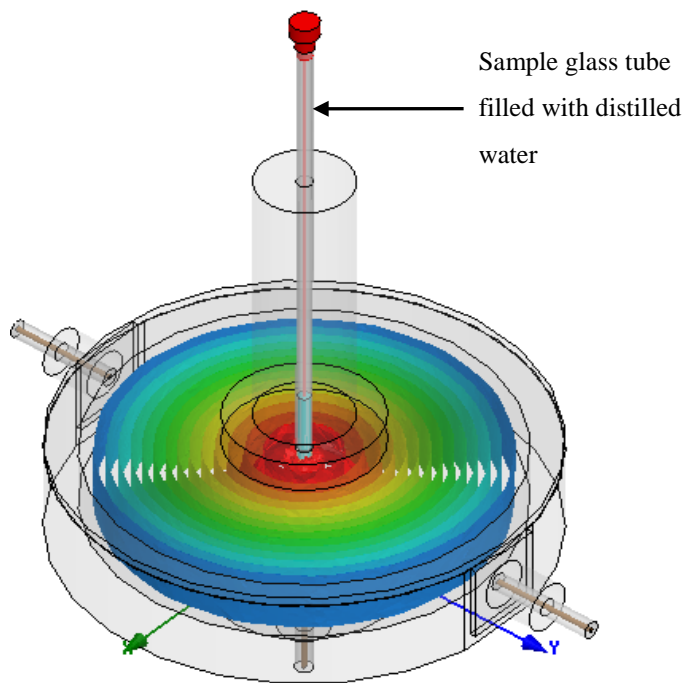

Figure 10: TM_{010} mode for small volume cavity with sample glass tube at centre.

V. CONCLUSIONS

Results from this work, which considers varying lactate concentrations in water, show that a linear response is possible when using microwave cavity sensors. The work has demonstrated the use of two different sensors, one which accommodates large volumes (10ml) and one which accommodates smaller volumes (0.5ml). Signal amplitude decreases by 0.04dB/mM when using large volume cavity, and increases by 0.067dB/mM when using the small volume cavity. Whilst these results alone would suggest that the small volume cavity provides better sensitivity *and* smaller sample size, it does not provide a stable resonant frequency and therefore may prove to be less precise than the large volume cavity.

Despite this finding, the work thus far suggests that microwave spectroscopy holds significant potential for the detection of issues during surgery when presented with CSF samples. Future elements of the work will include expanding into other clinically useful indicators in CSF such as albumin, glucose, lactate dehydrogenase (LDH), and consider the ability to rapidly scan biological fluids and tissues *ex-vivo* for cancer cells or tumour architecture. Ultimately however, the ability to gain useful information from microwave scans of tissues *in-vivo* could serve to avoid a range of invasive diagnostic procedures.

REFERENCES

- [1] M. Sellman, T. Ivert, G. Ronquist, K. Caesarini, L. Persson and B. K. Semb, "Central nervous system damage during cardiac surgery assessed by 3 different biochemical markers in cerebrospinal fluid", *Scandinavian journal of thoracic and cardiovascular surgery*, Volume 26, Issue 1, February 1992, pp.39-45. ISSN: 0036-5580
- [2] R. E. Anderson, A. Winnerkvist, L. Hansson, O. Nilsson, L. Rosengren , G. Settergren and J. Vaage, "Biochemical markers of cerebrospinal ischemia after repair of aneurysms of the descending and thoracoabdominal aorta", *Journal of Cardiothoracic and Vascular Anesthesia*, Volume 17, Issue 5, October 2003, pp. 598-603. doi:10.1016/S1053-0770(03)00203-9
- [3] F. Wadouh, C. F. Arndt, E. Oppermann, H. G. Borst and R. Wadouh, "The mechanism of spinal cord injury after simple and double aortic cross-clamping", *The Journal of Thoracic and Cardiovascular Surgery*, Volume 92, Issue 1, 1986, pp. 121-127. PMID:3724215

- [4] B. Drenger, S. D. Parker, S. M. Frank and C. Beattie, "Changes in cerebrospinal fluid pressure and lactate concentrations during thoracoabdominal aortic aneurysm surgery", *Anesthesiology*, Volume 86, Issue 1, January 1997, pp. 41–47. PMID:9009938
- [5] J. T. Strauch, et al., "Mild hypothermia protects the spinal cord from ischemic injury in a chronic porcine model", *European Journal of Cardio-Thoracic Surgery*, vol. 25, Issue 5, May 2004, pp. 708-715. doi:10.1016/j.ejcts.2004.01.007
- [6] I. Dujmovic and F. Deisenhammer, "Stability of cerebrospinal fluid/serum glucose ratio and cerebrospinal fluid lactate concentrations over 24 h: analysis of repeated measurements", *Clinical Chemistry and Laboratory Medicine*, Volume 48, Issue 2, February 2010, pp. 209-212. doi: 10.1515/CCLM.2010.040
- [7] R. M. C. Dawson, D. C. Elliott, W. H. Elliott and K. M. Jones, "Data for Biochemical Research, 3rd Edition", Oxford University Press, 1986. ISBN: 0198553587
- [8] D. Kajfez, "Temperature characterization of dielectric-resonator materials", *Journal of the European Ceramic Society*, vol. 21, Issue 15, pp. 2663-2667, 2001, doi:10.1016/S0955-2219(01)00341-7
- [9] H. Tamura, H. Matsumoto and K. Wakino, "Low temperature properties of microwave dielectrics", *Japanese journal of applied physics*, Volume 28, Suppl. 2, 1989, pp. 21-23. ISSN: 00214922
- [10] T. Konaka, M. Sato, H. Asano and S. Kubo, "Relative permittivity and dielectric loss tangent of substrate materials for high- T_c superconducting film", *Journal of Superconductivity*, Volume 4, Number 4, pp. 283-288. doi: 10.1007/BF00618150
- [11] J. Sheen, "Study of microwave dielectric properties measurements by various resonance techniques", *Measurement*, Volume 37, Issue 2, March 2005, pp. 123-130. doi:10.1016/j.measurement.2004.11.006
- [12] D. M. Pozar, "Microwave Engineering, 2nd Edition", John Wiley & Sons, Inc, 1998. ISBN: 0471170968
- [13] Ansoft Corporation, "Parametrics and Optimization using Ansoft HFSS", *Microwave Journal*, Product Reviews, Horizon House Publications, Inc., November 1999
- [14] D. M. Park and J. J. Choi, "Three-Dimensional Simulation of X-Band Coupled Cavity Traveling Wave Tube Amplifier", *Journal of the Korean Physical Society*, Vol.43, No. 6, Dec 2003, pp.1150-1111